

- 1.1 RAM-TEK-50 profile (item 1.1)
- 1.2 RAM-TEK-50 profile (item 1.1)
- 1.3 Spring (item 1.3)
- 2.1 OMODO-50 profile (item 2.1)
- 2.2 Locking bolt
- 3. Drywall screw\*\*
- 4. End cap for item 1.1\*
- 5. LED tape\*
- 6. Gland\*
- 7. Power supply (12 V / 24 V)\*
- 8. End cap for item 2.1\*

(Ref. 18059)

(Ref. 18053)

- 9. Bolt\*
- 10. Wedge\*
- 11. Cover\*
- 12. Silicone cord\*
- 13. Mounting tool for springs 1.3\*

\*The full range of accessories and electronics is available at [www.KlusDesign.eu](http://www.KlusDesign.eu)  
 \*\*Use screws suitable for the type of panel selected.

**NOTE!** All LED strips must be connected to a 12 V or 24 V power supply.

**IMPORTANT:** Not all possible mounting procedures are presented here. More mounting procedures and related accessories can be found at [www.KlusDesign.eu](http://www.KlusDesign.eu). Drawings of profiles and accessories in these instructions are simplified and only approximate the actual shapes

Ia

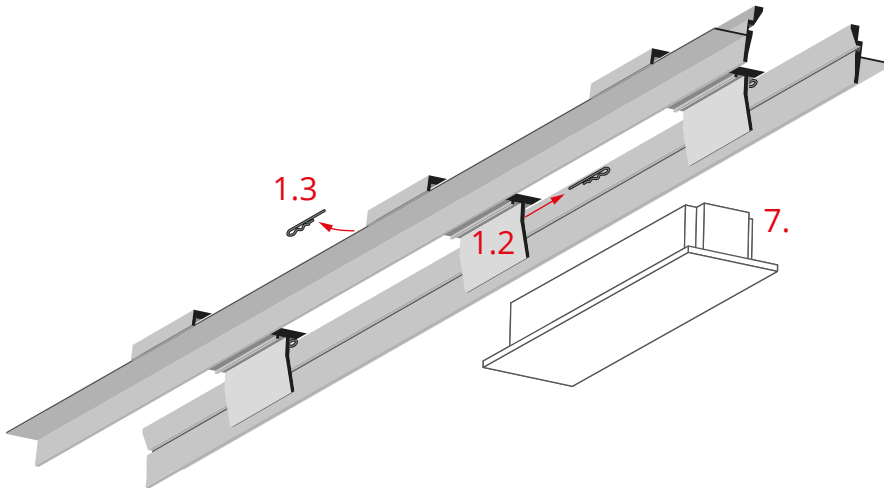

If the power supply (7) does not fit into the openings of the RAM-TEK-50 profile, its items (1.2) must be slid further apart accordingly.

To do this, remove the springs (1.3).

This can also be done after finishing the wet work.

Ila

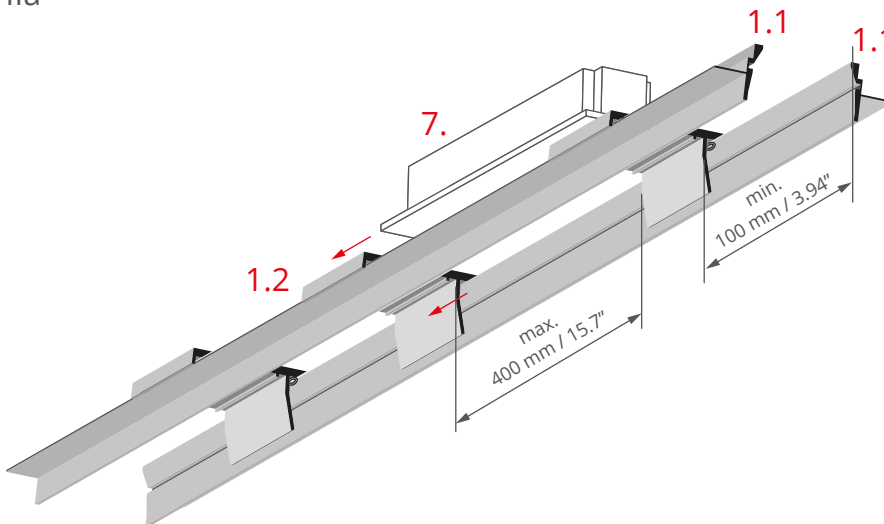

Slide the items (1.2) along the item (1.1).

The minimum distance of the last item (1.2) from the end of the profile is 100 mm / 3.94". The distance between items (1.2) cannot exceed 400 mm / 15.7".

After sliding items (1.2), make sure that the power supply (7) now fits into the enlarged opening.

IIla

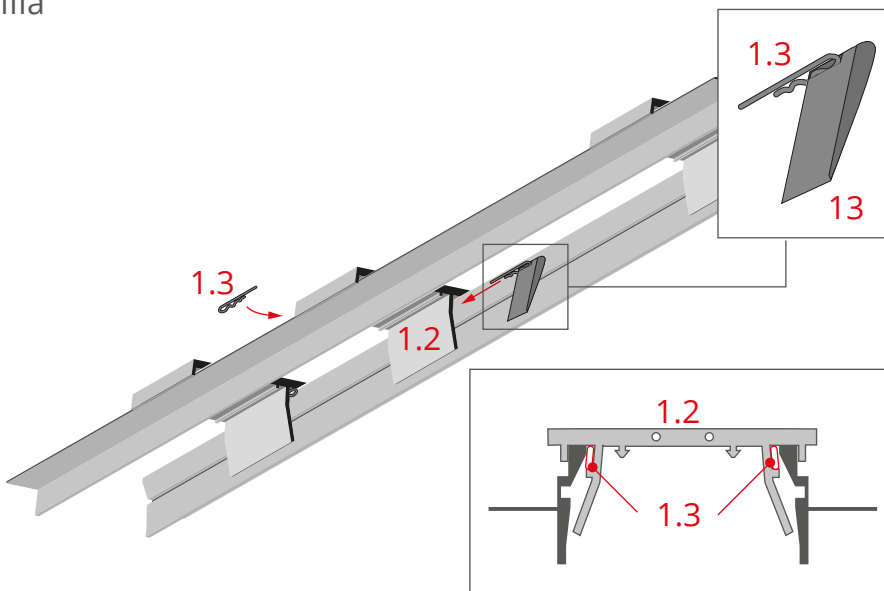

Put the springs (1.3) back in the items (1.2).

To assist, use the mounting tool for springs 1.3 (13).

Ib

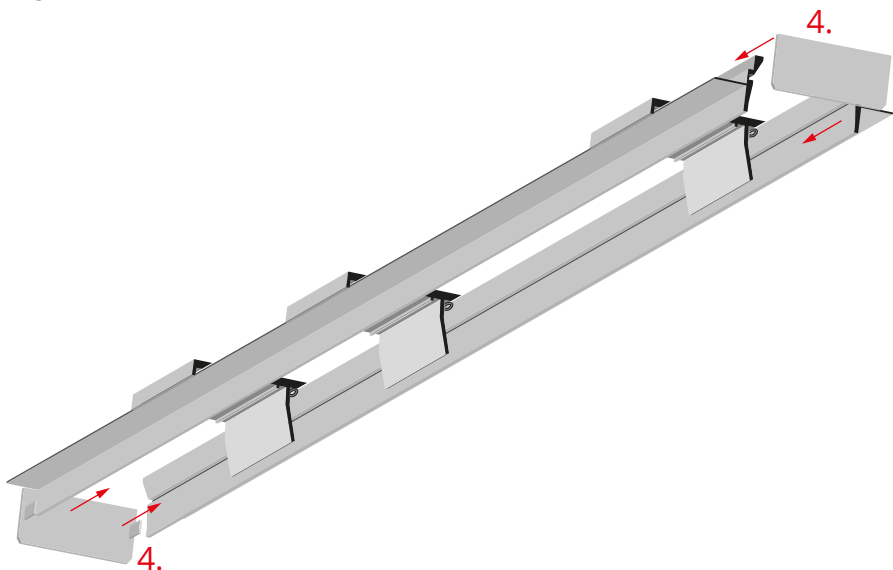

Attach end caps for item 1.1 (4).

IIb

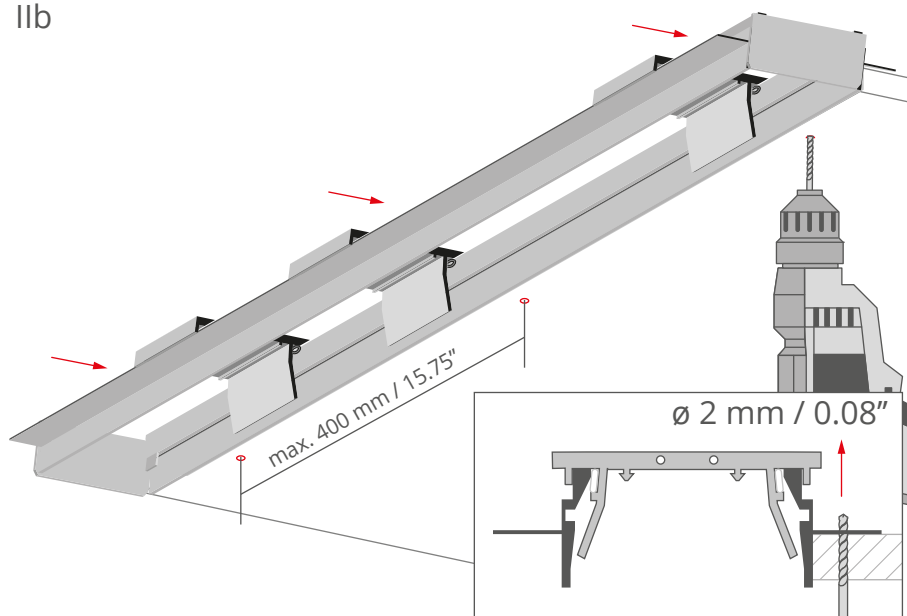

Put the profile to the edge of the drywall panel. Drill the holes through the panel and the profile's flange.

Maximum distance between the holes is 400 mm / 15.75".

**NOTE!** The profile must not get deformed during mounting!

IIIb

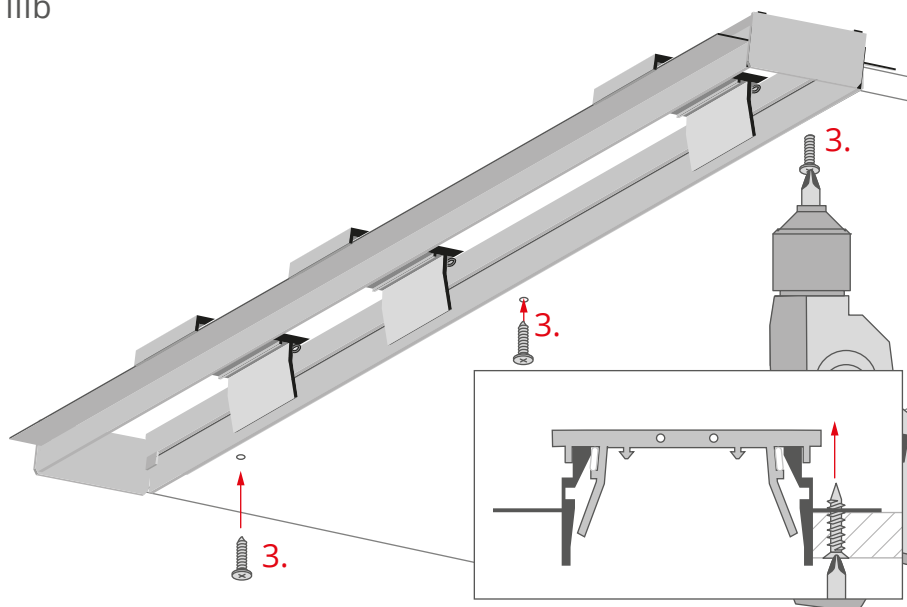

Insert the drywall screws (3) to pre-drilled holes and tighten the profile's flange to the drywall with them.

b) Groove preparation using the RAM-TEK-50 profile

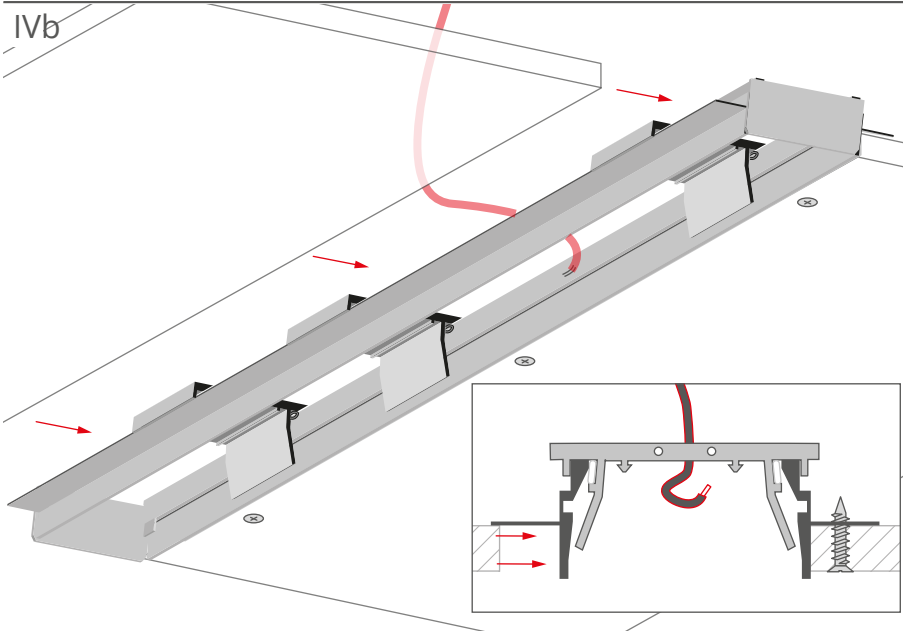

Place the second drywall against the profile. Lead the power cable through the openings in the profile.

**NOTE!** The profile must not get deformed during mounting!

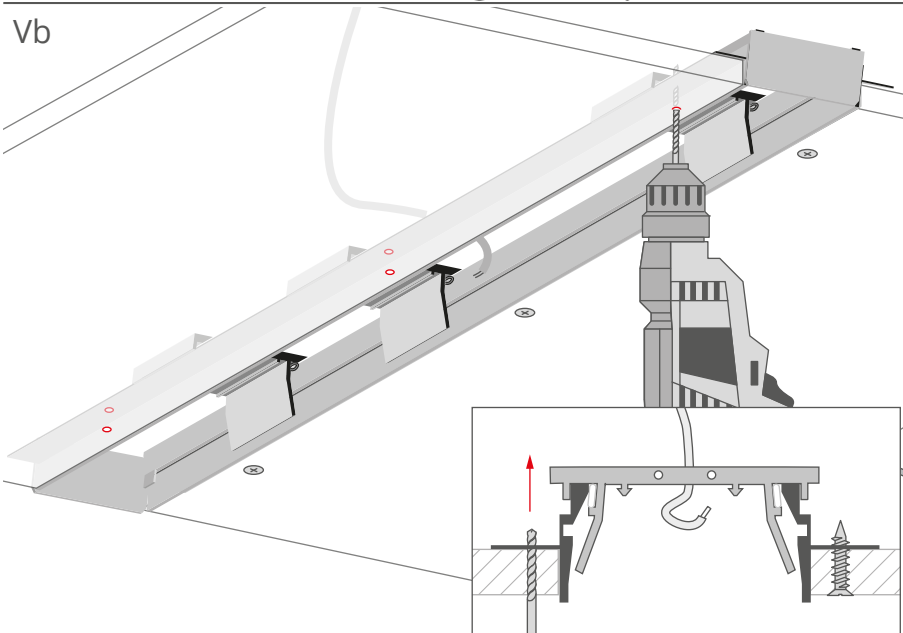

Drill the holes in the second panel and the profile's flange.

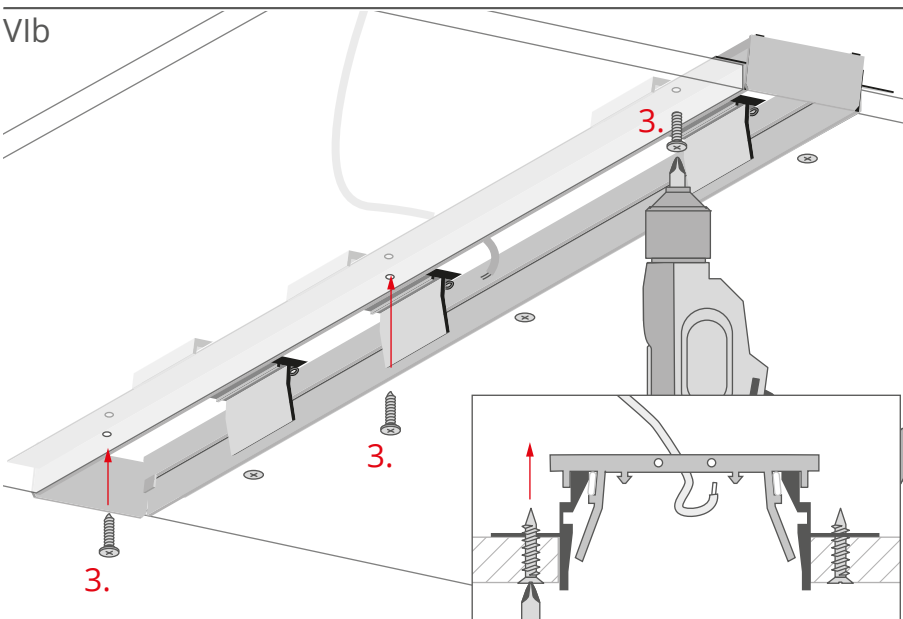

Insert the drywall screws (3) into the pre-drilled holes and tighten the second profile's flange to the drywall with them.

VIIb

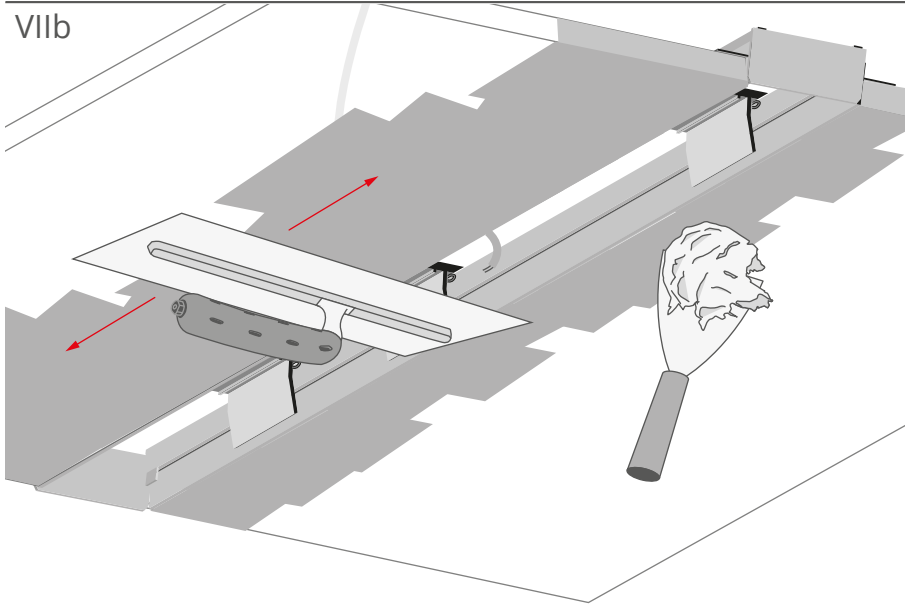

Apply plaster and make the surface even.

VIIIb

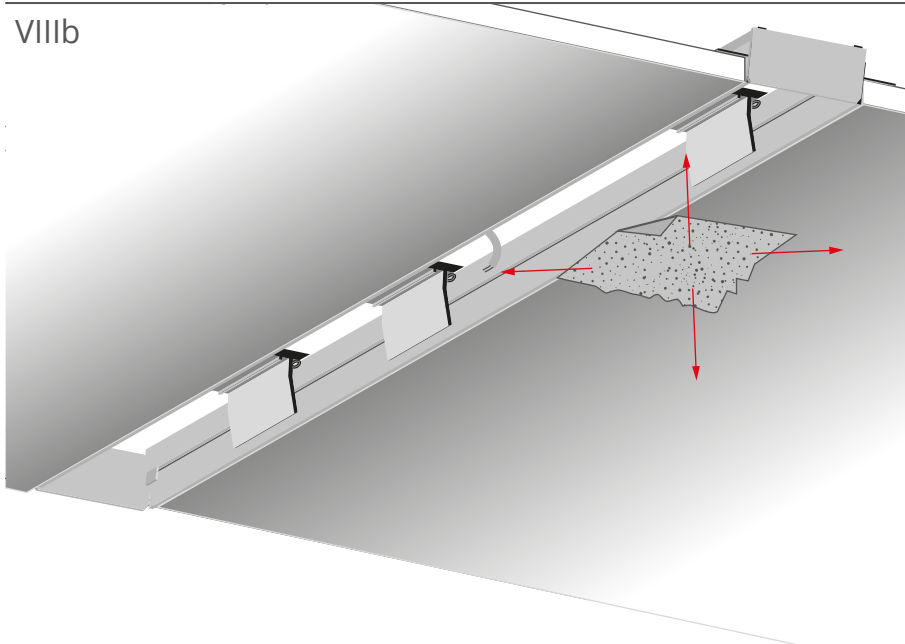

Smoothen the surface with sandpaper.

IXb

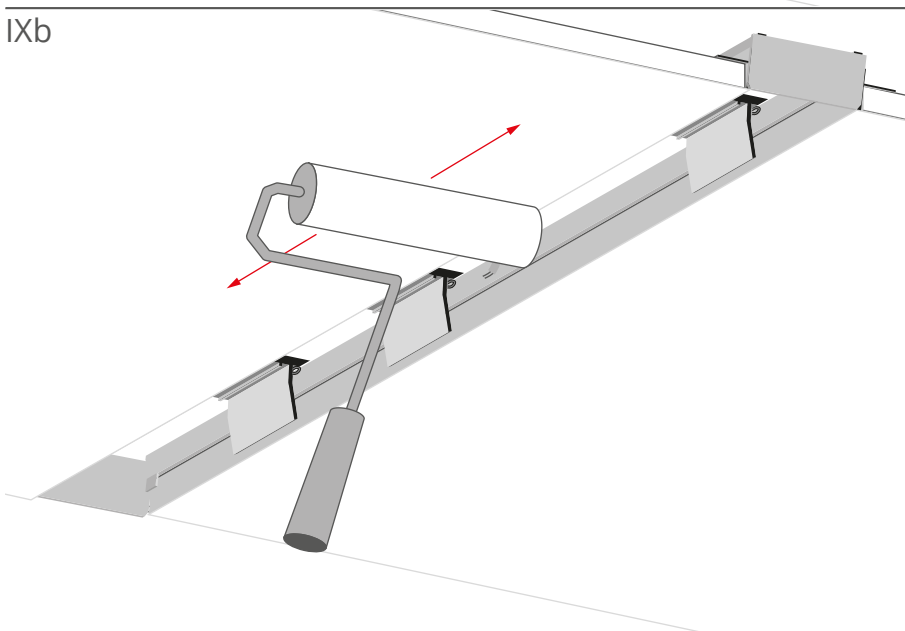

Prime and paint the surface.

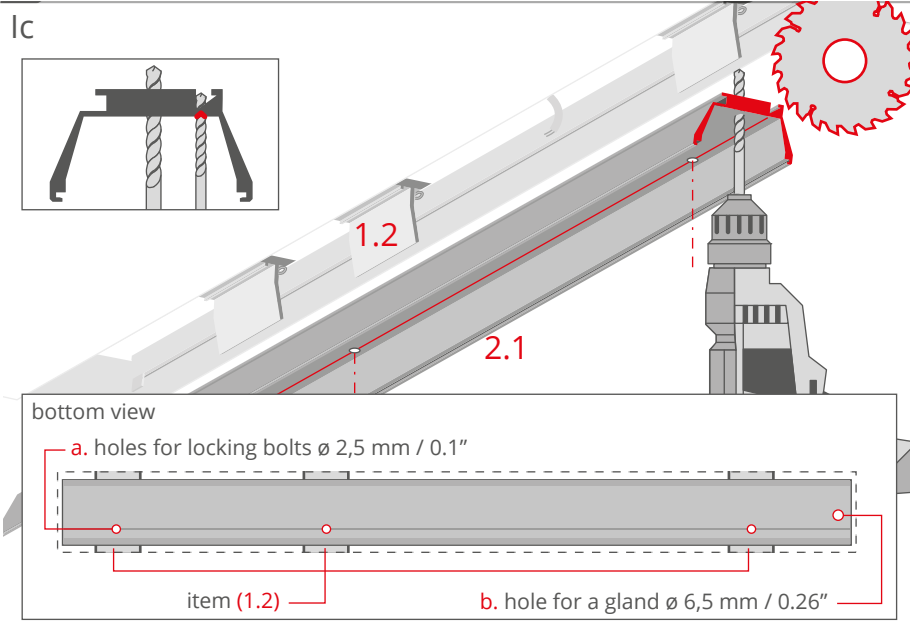

a. Drill holes for locking bolts in the profiled orientation line in the profile (2.1).

The number of holes must be equal to the number of bolts used. Each hole should be in the middle of the corresponding item (1.2). There must be a minimum of two bolts per 1 meter of a profile.

b. Drill a hole in the profile (2.1) for the cable gland.

**NOTE!** The profile (2.1) must be shortened by 6 mm / 0.24" at each end where the end caps will be mounted.

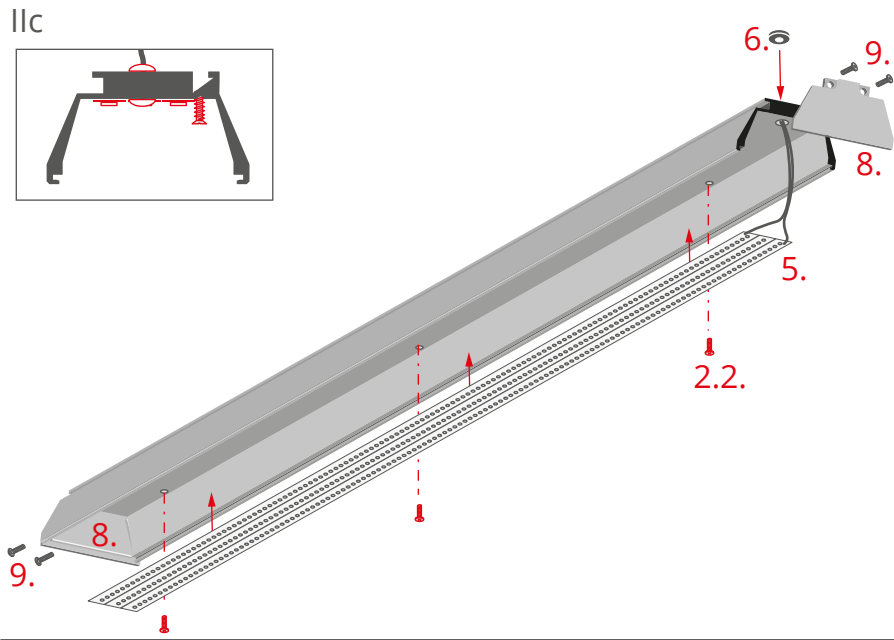

Adhere the LED tapes (5), mount the gland (6) and route the power cable through it.

Attach end caps to the item 2.1 (8) with the bolts (9).

Locking bolts (2.2) can be tightened preliminarily in the pre-drilled holes before mounting the profile at its destination (after mounting the LED tapes).

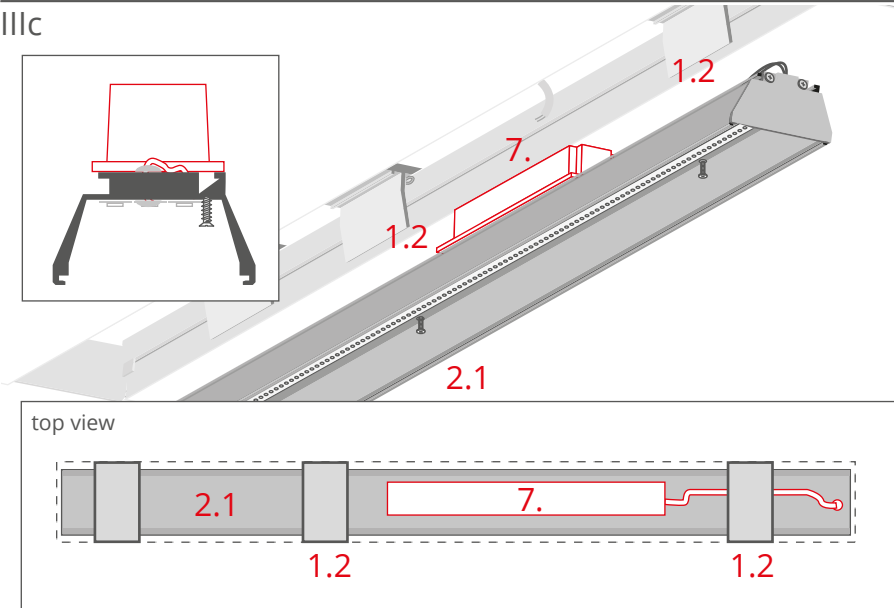

Mount the power supply (7) on the back of the profile in such a position that it fits into the opening of the RAM-TEK-50 profile.

Run the power cable to the power supply through one of the channels in the profile (2.1), so that it does not protrude above the surface.

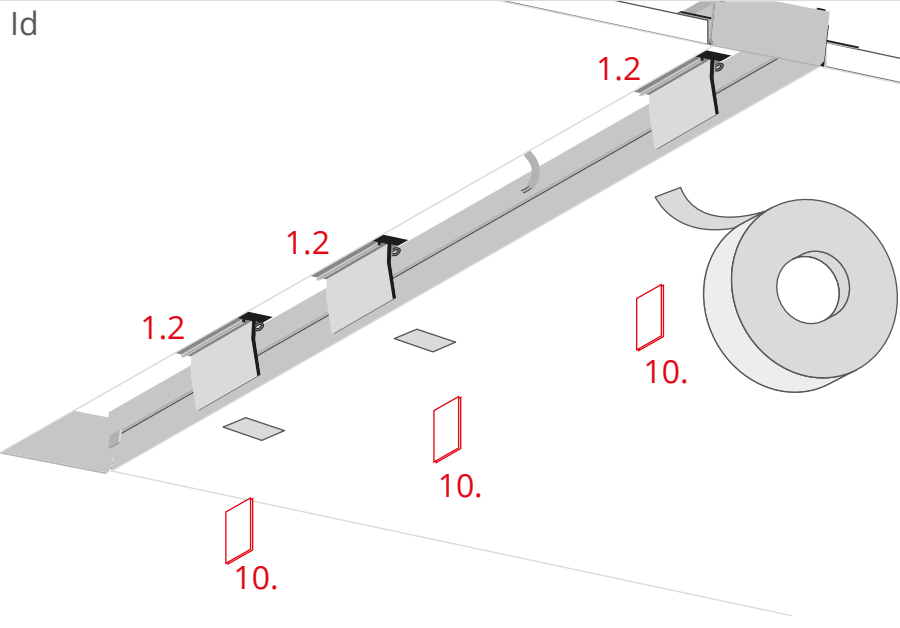

To facilitate further work, mark the location of the items (1.2) in the RAM-TEK-50 profile, e.g. with colored adhesive tape.

Prepare as many wedges (10) as there are items (1.2). They will prevent the OMODO-50 profile from falling out in the initial phase of the mounting procedure.

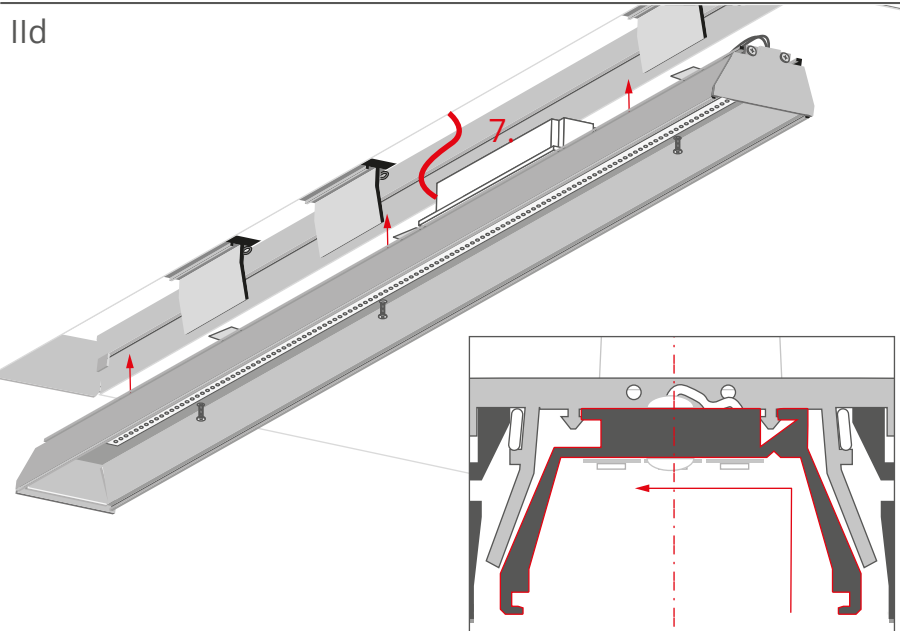

Connect the main power cables to the power supply (7).

Insert the OMODO-50 profile into the prepared mounting track.

To do so, press the profile to the wall of the RAM-TEK-50 from the side of the profiled orientation line. After that, press it to the item (1.2) and move it towards the axis of the RAM-TEK-50. This will make the hooks of the OMODO-50 profile interlock with the hooks of the items (1.2).

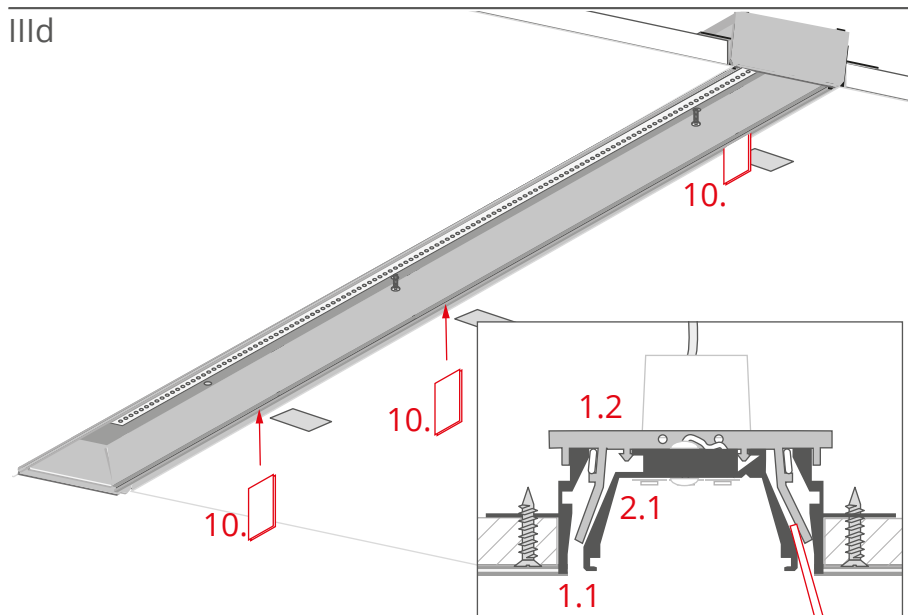

To prevent the OMODO-50 profile from falling out, insert wedges temporarily (10). They should be inserted into the marked spots in the gap between item (1.1) and item (2.1). There should be one wedge for each marked element (1.2) and they should be placed from the side of the profiled orientation line.

IVd

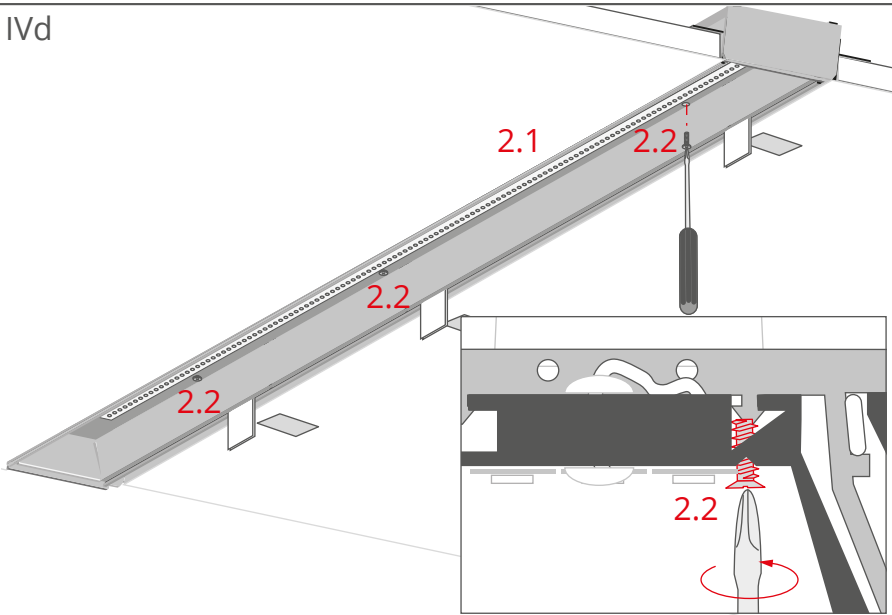

Secure the item (2.1) against slipping out by tightening the locking bolts (2.2) in the pre-drilled holes.

Vd

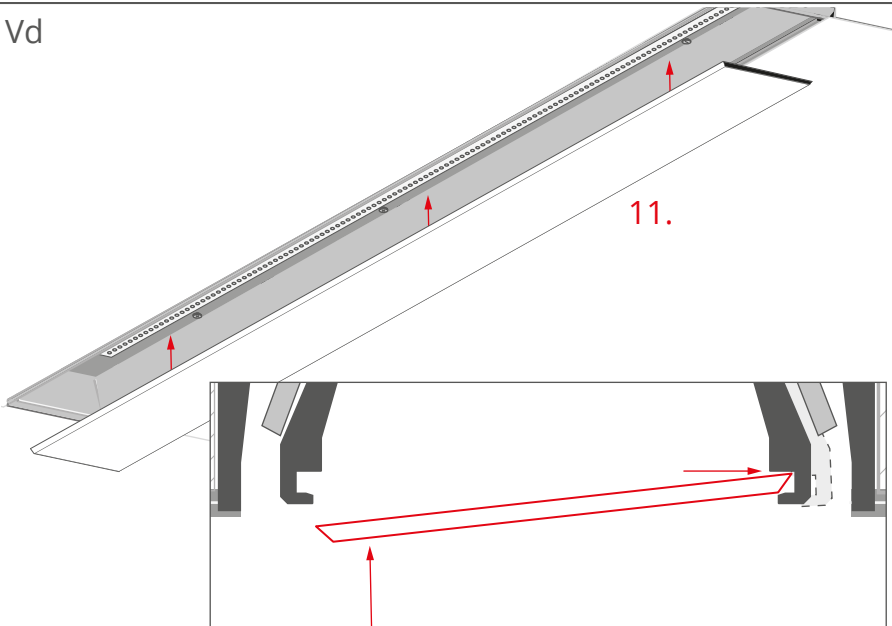

Remove wedges and markings.

Attach the cover (11) by slightly bending the edge of the profile outwards.

VId (opcjonalnie)

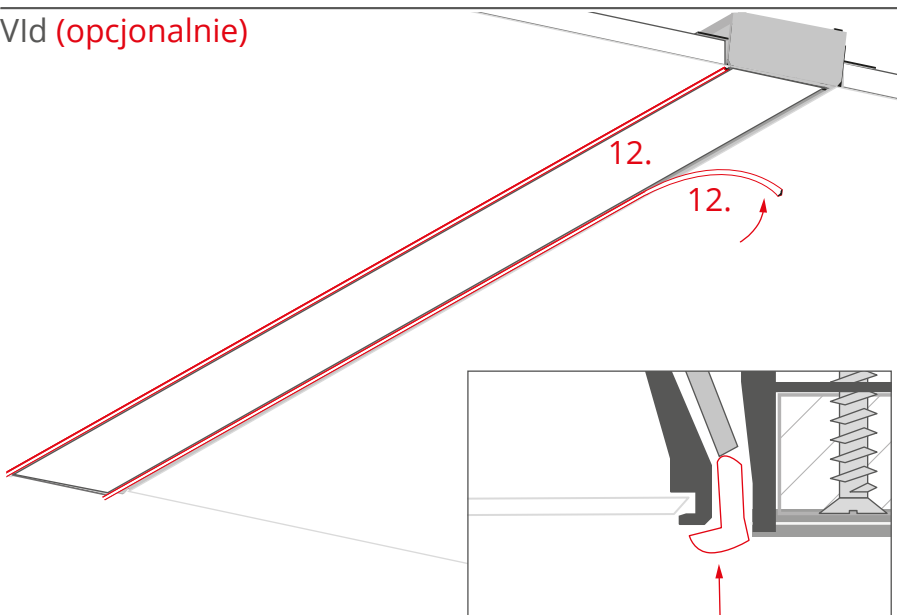

Mount the optional silicone cords (12).



**SERVICE**

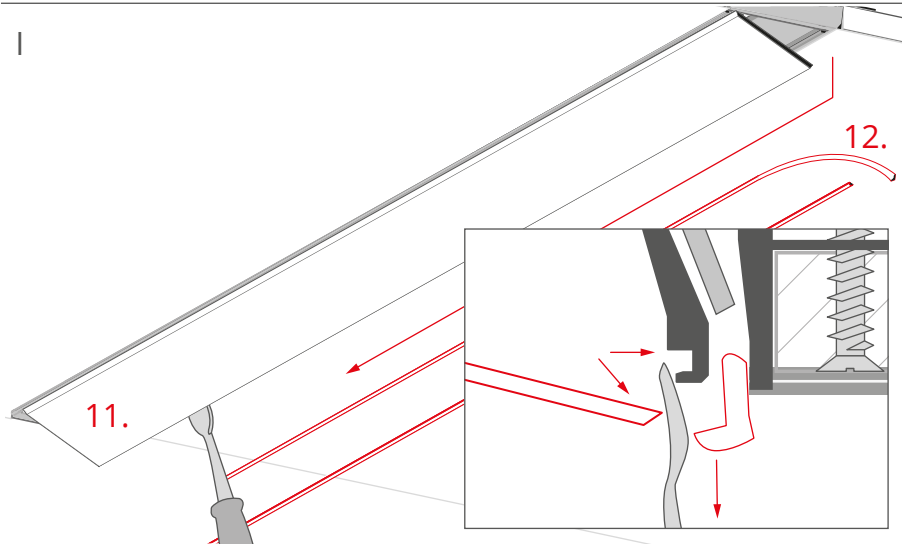

Remove the optional silicone cords (12).

Slightly bend the edge of the profile. Hook the edge of the cover (11) with a flat tool and slide the tool along the single edge of the profile so the cover will snap out.

**Do not bend the cover by force!**

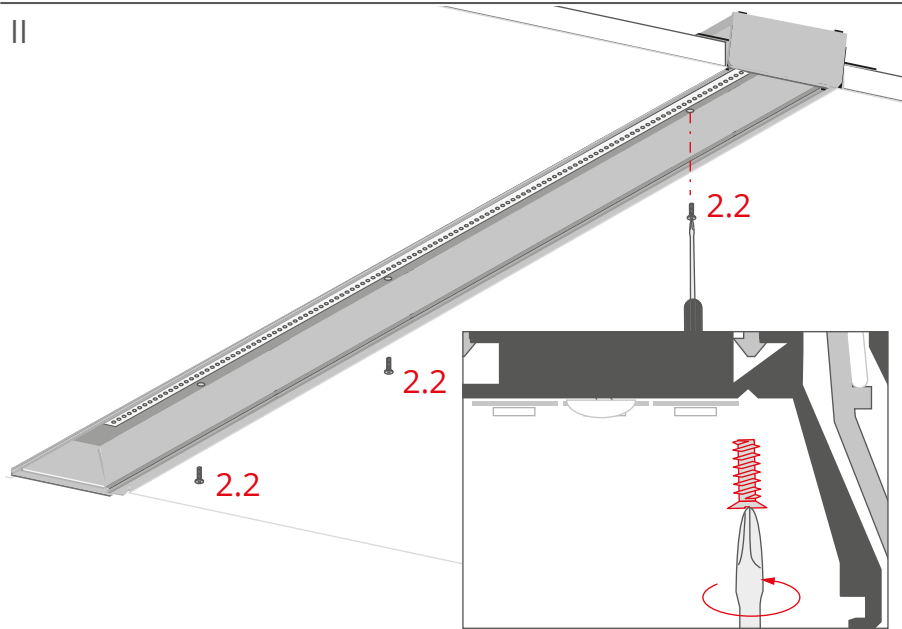

Remove the locking bolts (2.2).

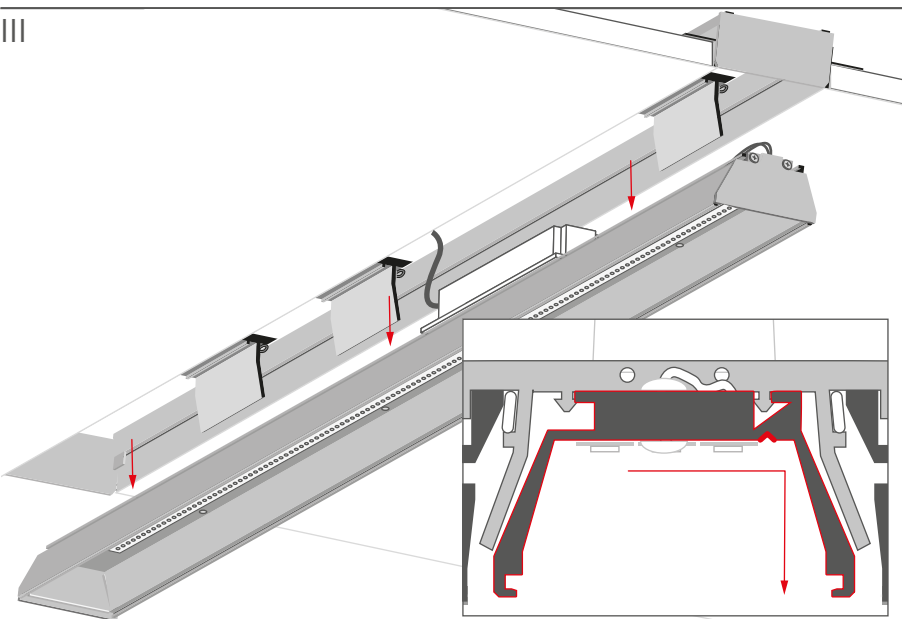

Slide the OMODO-50 profile towards the profiled orientation line and pull it down (as shown in the figure).